

Assembly Instruction for LC2-005WD-(WG4)

LOSS OF POWER INDICATOR
NO AC POWER, LED UNIT IS FLASHING
WITH AC POWER, LED UNIT IS DARK (NO LIGHT)

SUBASSEMBLY / PACKAGE CONTENTS: LC2-005WD (white LED), LC2-005WD-WG4 (white LED with Wago connector)

- O-Ring, 2 3/8 inch
- LED PCB subassembly, 4 wire, LC2-LPI-4WD, White LED
- Nut, Mounting, 2 3/8 inch
- Nut, Flange, grey, 2.5 inch
- 2 ea Warning Labels, adhesive backed
- Wago connector, 4 position, with wires attached (as required for LC2-005WD-WG4)
- Assembly Instruction/Installation Drawing AI-LC2-WD

PROCEDURE:

- 1) Prepare mounting hole in instrument housing, as required, with 2 3/8" diameter carbide cutter (not provided, GEMS Part Number IL-CHC2), remove burrs.
- 2) Begin disassembly of LPI package from rear. Remove grey flange nut.
- 3) Remove LED PCB subassembly from lens.
- 4) Unscrew 2 3/8" flange nut from lens.
- 5) Insert lens into hole aligning it so the rib on the rim of the lens is at the top position and the two fish-eye lens are in a horizontal position.
- 6) Secure the lens in position using the 2 3/8" mounting nut and seal the O-Ring against the outside of the building. Note: Attach warning labels as required.
- 7) Insert the LED subassembly unit into the lens aligning the hole in the washer with the alignment pin on the bottom of the lens.
- 8) Hold the unit in place by finger tightening the grey socket flange nut, usually about one turn onto the back of the lens.
- 9) Check LED assembly outside of the lens surface to assure the LEDs are visible through the fish-eye lens.
- 10) Attach the two blue wires of the unit across 110 or 220 VAC 60 Hz. If Wago connector used, follow drawing instruction.
- 11) Attach the red wire to the "plus" side of the battery bus, 13.6 VDC typical. and the black wire to the "minus" side of the battery bus (SYSTEM GROUND). If Wago connector used, follow drawing instruction.
- 12) TEST: Turn the DC power on (remove AC power) and check to see the LED unit is illuminated in the flashing mode, (approximately one flash per second, half on - half off). INDICATES LOSS OF AC POWER.
- 13) TEST: Attach and power on the AC (with DC power on) and check to see the LED unit is operating in the off (no light) mode. INDICATES AC POWER PRESENT.

**INSTALLATION DRAWING
LC2-005WD, LC2-005WD-WG4**

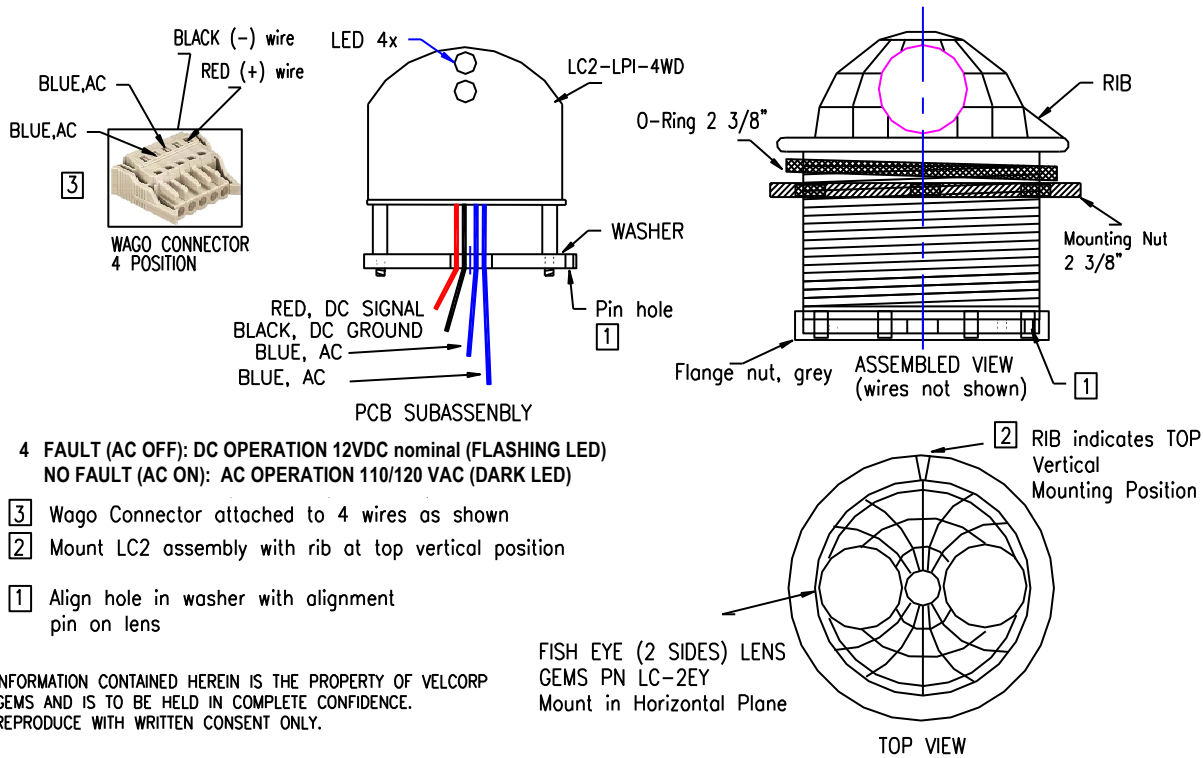

4 FAULT (AC OFF): DC OPERATION 12VDC nominal (FLASHING LED)
NO FAULT (AC ON): AC OPERATION 110/120 VAC (DARK LED)

- 3 Wago Connector attached to 4 wires as shown
- 2 Mount LC2 assembly with rib at top vertical position
- 1 Align hole in washer with alignment pin on lens

INFORMATION CONTAINED HEREIN IS THE PROPERTY OF VELCORP
GEMS AND IS TO BE HELD IN COMPLETE CONFIDENCE.
REPRODUCE WITH WRITTEN CONSENT ONLY.