

Assembly Instruction for LC2-002WR-LA-(WG2), LC2-002WR-LA-(R,A,G,B)

DC OPERATION ONLY

SUBASSEMBLY / PACKAGE CONTENTS: LC2-002WR-LA (white LED), LC2-002WR-LA-WG2 (white LED with Wago connector), LC2-002WR-LA-(R,A,G,B) (red or amber or green or blue LED)

- O-Ring, 2 3/8 inch
- LED subassembly, 2 wire, LC2-LPI-2WR-(W,R,A,G,B), White, Red, Amber, Green, Blue LED
- Nut, Mounting, 2 3/8 inch
- Nut, Flange, grey, 2.5 inch
- Wago connector, 2 position, with wires attached (as required for LC2-001WB-WG2)
- Drawing LC2-002WR

PROCEDURE:

- 1) Prepare mounting hole in instrument housing, as required, with 2 3/8" diameter carbide cutter (not provided, GEMS Part Number IL-CHC2), remove burrs.
- 2) Begin disassembly of package from rear. Remove grey flange nut.
- 3) Remove LED subassembly from lens.
- 4) Unscrew 2 3/8" flange nut from lens.
- 5) Prepare 2.4"-2.5" mounting hole in the building at desired location if one is not present.
- 6) Insert lens into hole aligning it so the rib on the rim of the lens is at the top position and the two fish-eye lens are in a horizontal position.
- 7) Secure the lens in position using the 2 3/8" mounting nut and seal the O-Ring against the outside of the building.
- 8) Insert the LED subassembly unit into the lens aligning the hole in the washer with the alignment pin on the bottom of the lens.
- 9) Hold the unit in place by finger tightening the grey socket flange nut, usually about one turn onto the back of the lens.
- 10) Check LED assembly outside of the lens surface to assure the LEDs are visible through the fish-eye lens.
- 11) Attach the red wire to the "plus" side of the battery bus, and the black wire to the "minus" side of the battery bus (SYSTEM GROUND). If Wago connector used, follow drawing instruction.
- 12) TEST: Turn the DC power on and check to see the LED unit is illuminated.

INSTALLATION DRAWING
LC2-002WR-LA, LC2-002WR-LA-WG2, LC2-002WR-LA-(R,G,A,B)

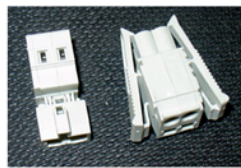

3

WAGO CONNECTOR
2 POSITION

RED, (+) SIGNAL

BLACK, (-) GROUND

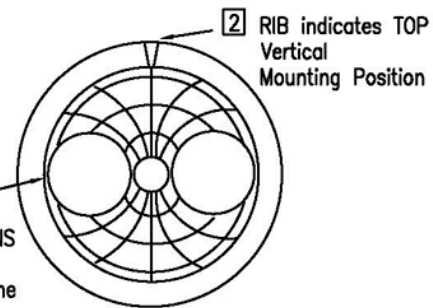
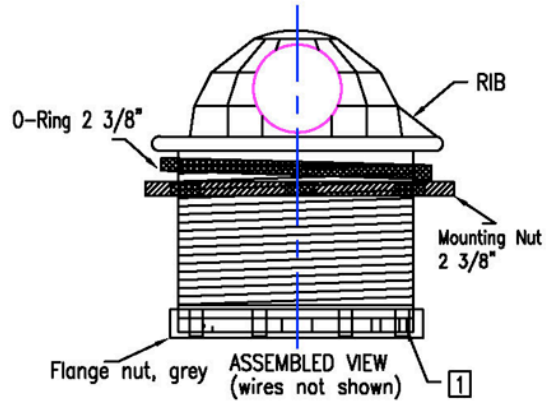
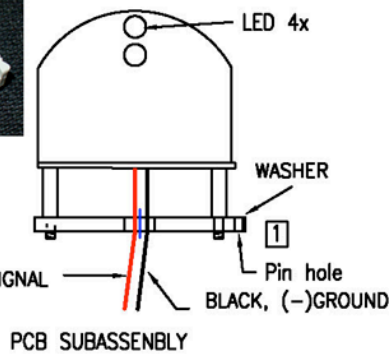

TOP VIEW

- 4 DC OPERATION 12VDC nominal (STEADY ON LED)
- 3 Wago Connector attached to 2 wires as shown
- 2 Mount LC2 assembly with rib at top vertical position
- 1 Align hole in washer with alignment pin on lens

INFORMATION CONTAINED HEREIN IS THE PROPERTY OF VELCORP GEMS AND IS TO BE HELD IN COMPLETE CONFIDENCE. REPRODUCE WITH WRITTEN CONSENT ONLY.

FISH EYE (2 SIDES) LENS
GEMS PN LC-2EY
Mount in Horizontal Plane